

6E3090

Roll No. _____

Total No of Pages: 7

6E3090

B. Tech. VI Sem. (Main & Back) Exam. May/June-2014
Electronics & Communication Engineering
6EC5 Control Systems
Common with AI

Time: 3 Hours

Maximum Marks: 80

Min. Passing Marks: 24

Instructions to Candidates:-

Attempt any five questions, selecting one question from each unit. All Questions carry equal marks. Schematic diagrams must be shown wherever necessary. Any data you feel missing may suitably be assumed and stated clearly.

Units of quantities used/ calculated must be stated clearly.

Use of following supporting material is permitted during examination.

1. _____

2. _____

UNIT-I

Q.1. (a) Obtain the overall transfer function for a system represented by the block diagram. [6]

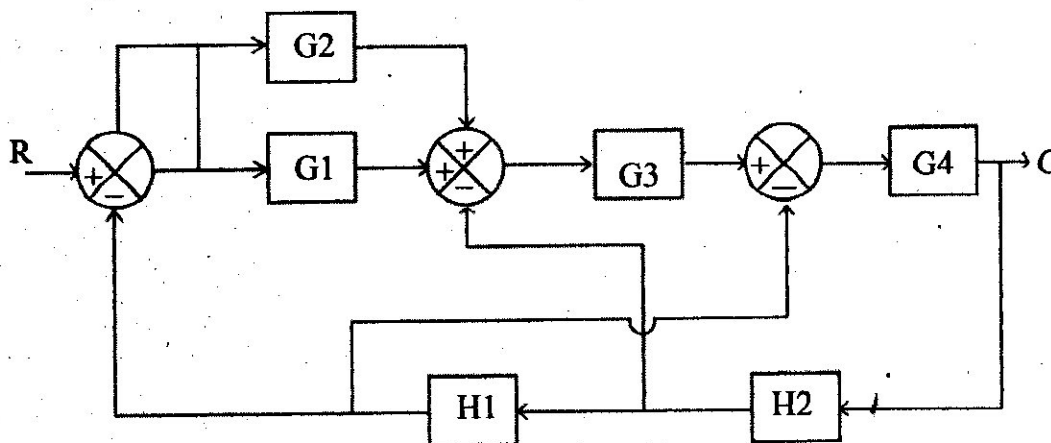

fig.1(a)

Q.1. (b) Fig. 1(b) shows a positional control system for controlling the position of a shaft. The potentiometer error detector measures the deviation of the output shaft w.r.t. reference position O_r . The error is amplified by mean of an amplifier, the output of which is fed to an armature controlled dc motor. The motor shaft is coupled to the load shaft through a gear. The system parameters are as follows;

Error detector gain $K_e = 2 \text{ V/rad}$,

Amplifier gain $K_A = 10\text{V/V}$, $R_a = 0.2 \text{ Ohm}$, $L_a = \text{negligible}$,

Motor Torque constant $K_T = 10^{-4} \text{ V/(red/sec.)}$.

Equivalent moment of inertia referred to motor side $J_m = 10^{-4} \text{ Kg-m}^2$.

Equivalent co-efficient of viscous friction referred to motor side $f_m = 10^{-4} \text{ Nm/(rad/sec)}$

Draw the block diagram and determine the overall transfer function relating the output & input. [10]

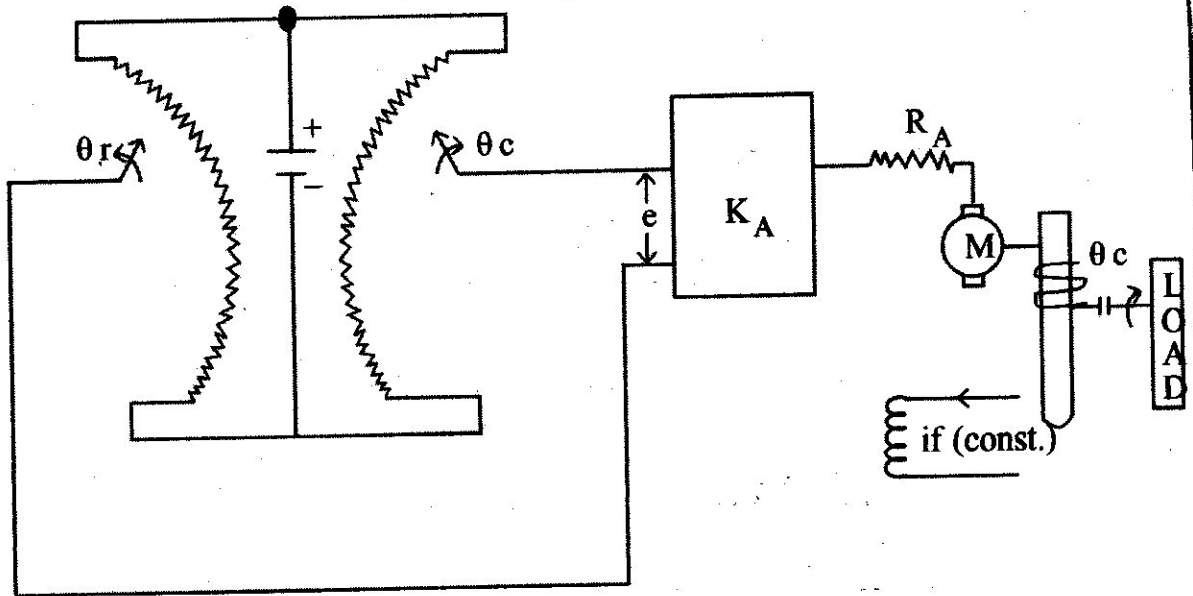

fig.1(b)

OR

Q.1. (a) The block diagram representation of a control system is shown below -

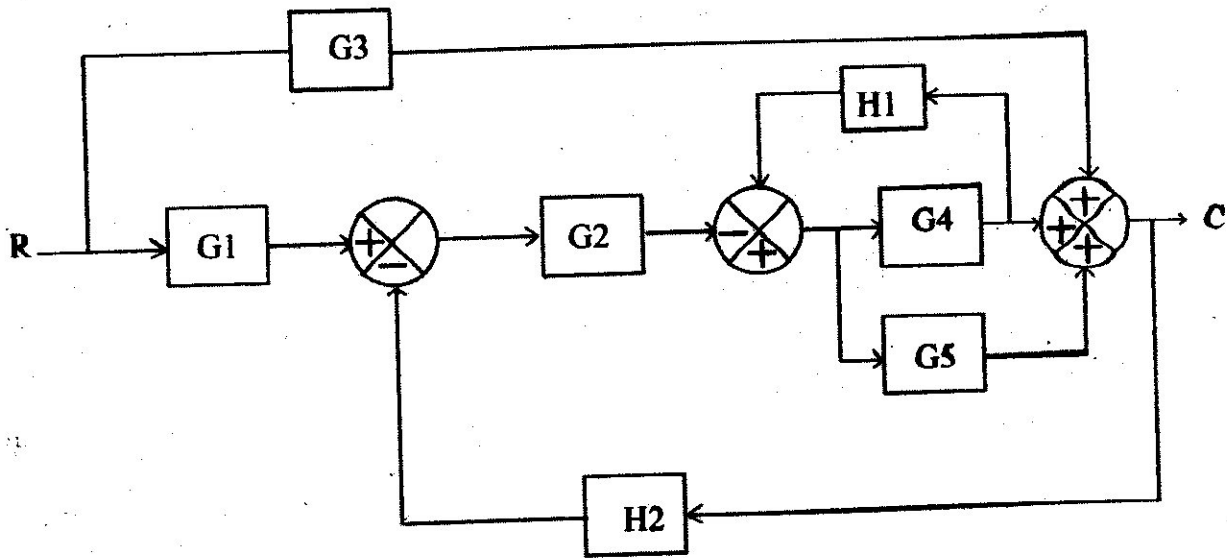

fig.1(a)

Obtain overall transfer function.

[8]

Q.1. (b) (i) Find the inverse z-transform of -

$$\frac{4z^2 - 2z}{z^3 - 5z^2 + 8z - 4}$$

(ii) Solve the differential equation -

$$x(k+2) - 3x(k+1) + 2x(k) = 4^k ; \quad x(0)=0, \quad x(1)=1$$

[8]

UNIT-II

Q.2. (a) A unity feedback control system has

$$G(s) = \frac{1}{s(s+2)}$$

The input to the system is given by $r(t) = 2+3t+2t^3$. Determine the generalized error coefficients and steady state error. [8]

Q.2. (b) A unity feedback control system is shown in Fig 2(b), By using deviative control, the damping ratio is to be made 0.8. Determine the value of T_d and compare the rise time, peak time and maximum overshoot for the system -

(i) without derivative control, (ii) with derivative control. The input to the system being unity. [8]

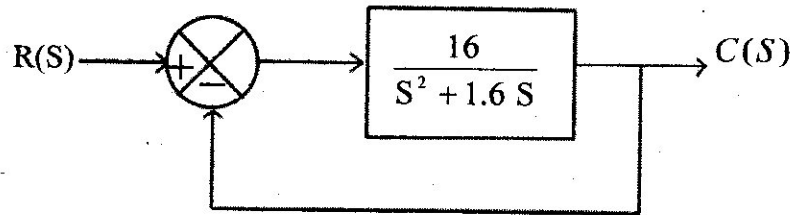

Fig.2(b)

OR

Q.2. (a) A second order control system is represented by a transfer function given below.

$$\theta_o(s) = 1, \quad T(s) = J s^2 + fs + k$$

Where θ_o = proportional output, T = input torque

A step input of 10Nm is applied to the system and test results are given below -

- (i) $M_p = 6\%$
- (ii) $t_p = 1 \text{ sec.}$,
- (iii) Steady state value of J, f & k [8]

Q.2. (b) Derive the expression for "Time response of a second order system subjected to unit step input function". [8]

UNIT-III

- Q.3. (a) (i) Determine the gain K such that the G.M. = 6db. The feedback control system transfer function is given below -

$$G(s)H(s) = \frac{K}{s(s^2 + 2s + 5)}$$

- (ii) Determine the value of phase margin for the value of K obtained as above.

[8]

- Q.3. (b) The transfer function of a unity feedback control system is given below -

$$G(s)H(s) = \frac{720(s+1.25)}{s(s+10)(s^2 + 2s + 9)}$$

Determine the closed loop stability using Bode Plot Method.

[8]

OR

- Q.3. The block diagram of a Robot Joint Control is shown in fig.3. Various control parameters are -

$$J = 10 \text{ kg/m}^2, f = 20 \text{ Nm/rad/sec.}$$

$$\text{Motor Torque Constant } K_m = 2 \text{ Nm/V}$$

$$\text{Velocity feedback constant } K_v = 1 \text{ V/rad/Sec.}$$

Error amplification K_e (in V/degree), to be determined.

- (i) Calculate the value of K_c for the closed loop system to have $\zeta = 1$.
- (ii) Determine the steady state error $\theta_e(s)$ when $\theta_d(s) = 0$ and load torque of 5 Nm is suddenly applied.

(iii) Determine $\theta_e(s)$ when $T_s = 0$ and input θ_d is unit step. [16]

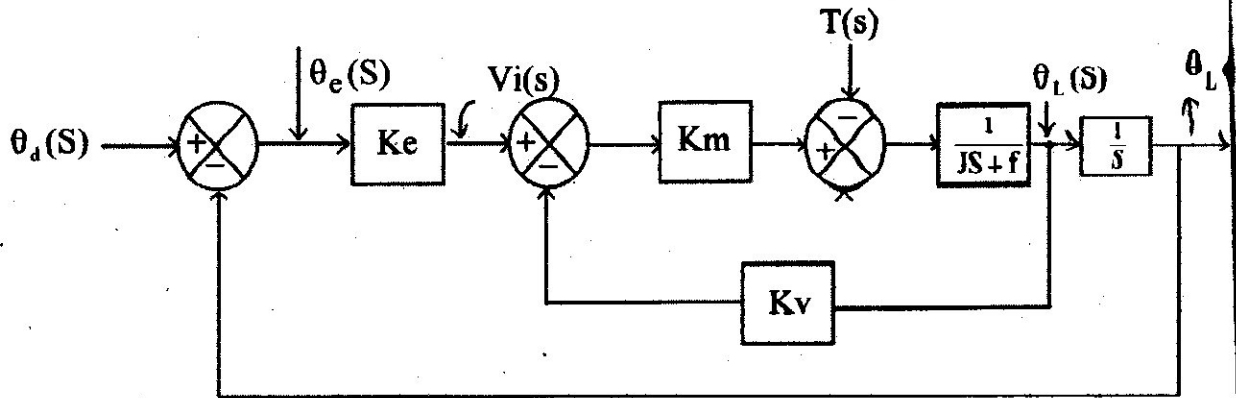

Fig. 3.

UNIT-IV

Q.4. (a) The open loop transfer function of a unity feed- back control system is given below;

$$G(S) = \frac{(S+0.25)}{S^2(S+1)(S+0.5)}$$

Determine the closed loop stability by using Nyquist Criteria [8]

Q.4 (b) (i) Determine the stability of a closed loop system whose characteristics equation is -

$$S^5 + S^4 + 2S^3 + 11S + 10 = 0$$

(ii) Determine the stability of a system having following characteristic eqn [8]

$$S^6 + S^5 + 5S^4 + 3S^3 + 2S^2 - 4S - 8 = 0$$

OR

Q.4 (a) Sketch the Root-Locus plot for the open-loop transfer function given below-

$$G(S)H(S) = \frac{K(s^2 + 4)}{s(s+2)}$$

Calculate the value of K at -

(i) Breakaway Point

(ii) $s = -0.69 + j0.9$

[10]

Q.4 (b) (i) What is Hurwitz Stability Criterion? Explain it with suitable example.

(ii) Write a short note on absolute stability and relative stability.

[6]

UNIT-V

Q.5 (a) What is the concept of controllability and observability. Explain both with suitable example and mathematical expressions.

[10]

(b) Obtain the state equations for the field controlled d.c. motor shown in fig. 5 (b) below -

[6]

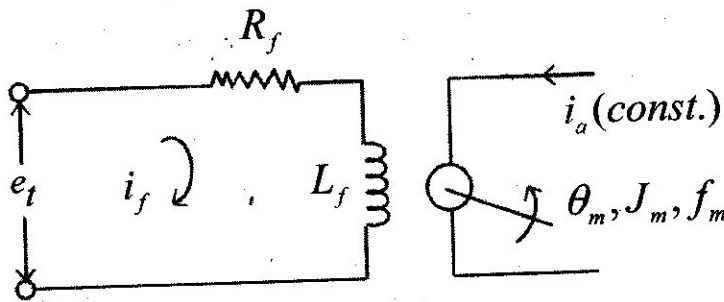

Fig.5(b)

OR

Q.5 (a) For the system given below obtain -

(i) Zero input response

(ii) Zero state response

(iii) Total response

$$\dot{x} = \begin{bmatrix} 0 & 1 \\ -2 & -1 \end{bmatrix} x + \begin{bmatrix} 0 \\ 1 \end{bmatrix} u(t)$$

Where $x_1(0) = 1$, $x_2(0) = 0$ and $u(t) = 1$

[8]

(b) Give the brief idea of state variable analysis in discrete time domain with suitable examples.

[8]